

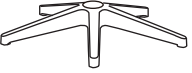

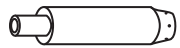



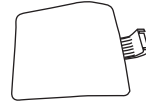
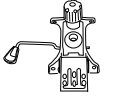
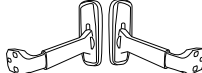

# OFFICE CHAIR

KARBONE 1804-  ITEK  
SIÈGES DE BUREAU

A		5
B		1
C		1
D		1
E		1
F		1
G		2

H	 M6x20mm	4
I	 M6x30mm	6
L	 M8x20mm	3
J	 $\Phi 6$	10
K	 $\Phi 8$	3
M		1

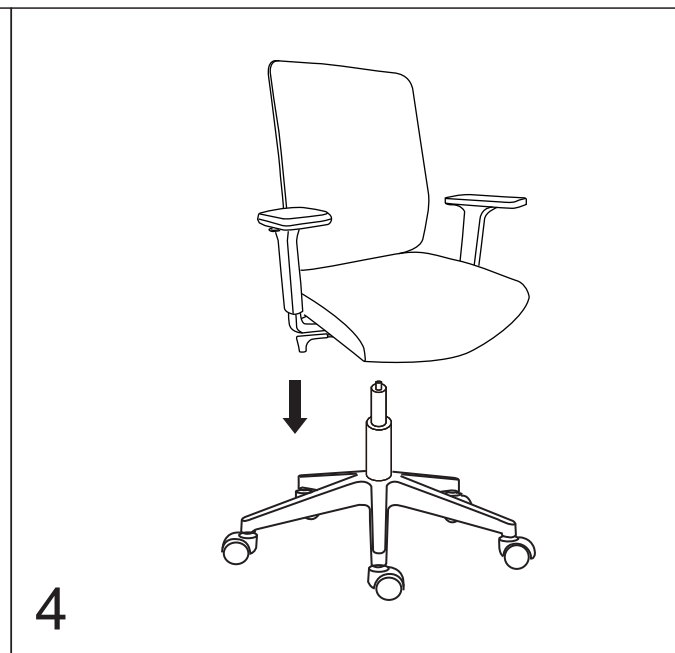
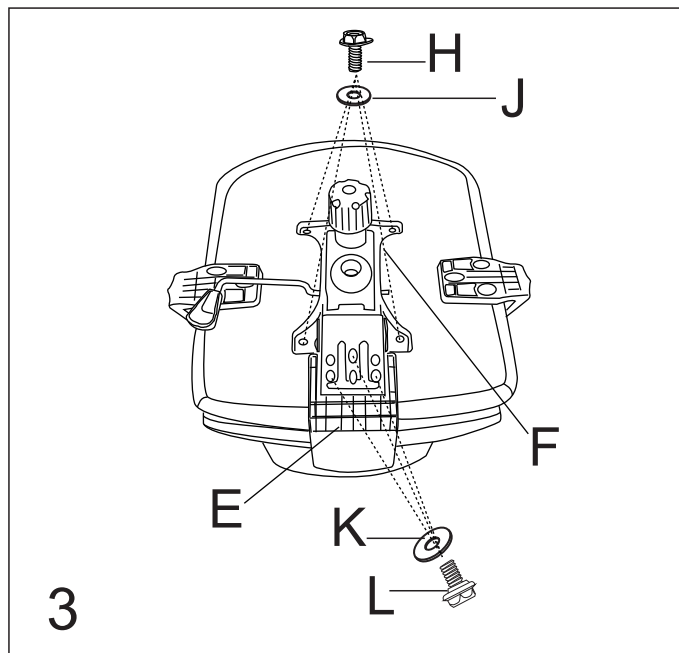
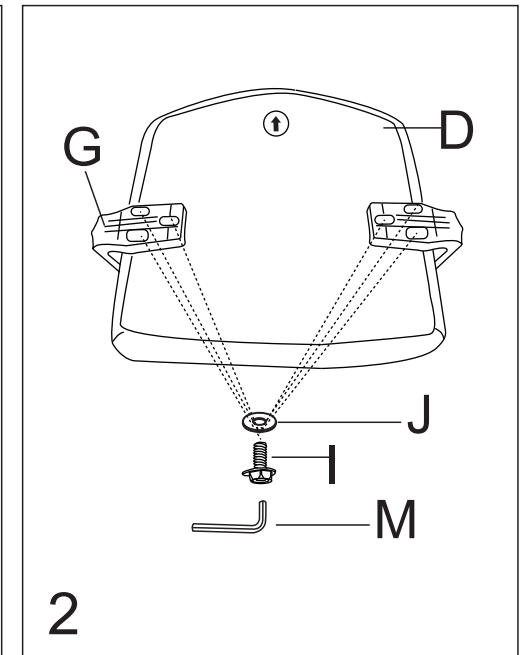
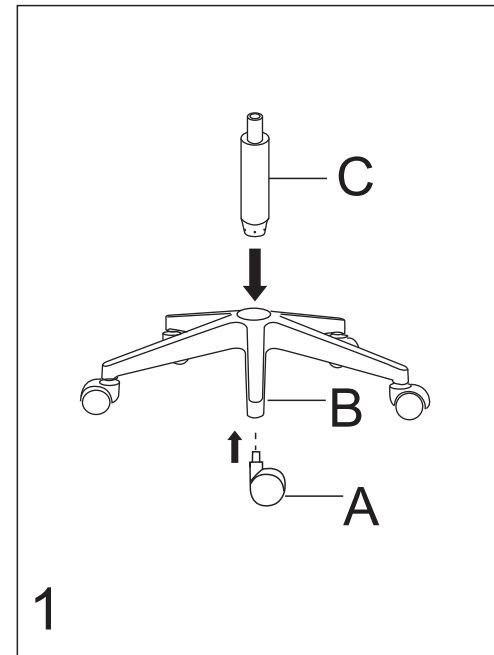

# OFFICE CHAIR

---

---

## Warning:

1. Don't use the chairs as the ladder to get the objects on the high position. It's so dangerous to stand on the chairs.
2. Don't let the children play on the chairs, rotating the chairs incessantly will cause injury to the children.
3. All plastic packing bags must be disposed properly. Don't let the children have chance to touch the plastic packing bags, it may result in causing the children to asphyxiate.
4. Don't lean so far back in your chairs that the wheels or legs lift up off the floor. Leaning can cause the chair to slip out from under you, cause structural damage, or can loosen important connections that can cause the chair to fall apart.
5. Never put all your weight at the very front edge of the chair. If you sit too far forward, the chair can tip over. Use a chair with a forward tilt mechanism if the task requires sitting in a forward position.
6. Don't leave electrical appliances on upholstered chairs. Fire can result if they overheat. Be careful when smoking cigarettes or carrying lighted material around upholstered chairs.
7. Don't overwork your chairs. Inspect and maintain your chairs at least 60 days.

## Do's:

1. Always follow the assembly direction completely. Make sure all the pieces are placed in the proper order so that the chair stays tight and together.
  2. Pay special attention to make sure the casters or wheels are fully inserted into the base of the unit.
  3. Every 6 month or so, make sure all the parts of the chair are tightened to ensure stability.
  4. Always keep the base of the chair completely on the floor.
  5. Always ensure that the tension control is properly adjusted, resulting in a smooth and controlled motion.
- 
-